

**DESCRIPTION**

A solenoid-operated, two-way, normally open, poppet-type, screw-in hydraulic cartridge valve, designed to function as a load holding or blocking valve in applications requiring low internal leakage.

**OPERATION**

When de-energized, the INSV16-23 poppet lifts to open the 2 to 1 flow path. In this mode, flow from 1 to 2 is also allowed. When energized, the cartridge acts as a check valve, allowing flow to pass from 1 to 2, while blocking flow in the reverse direction after overcoming the solenoid force (requires 3.4 to 10.3 bar / 50 to 150 psi).  
**Operation of Manual Override Option:** To override, push and hold override button.

**FEATURES**

- Continuous-duty rated solenoid.
- Hardened seat for long life and low leakage.
- Optional coil voltages and terminations.
- Efficient wet-armature construction.
- Cartridges are voltage interchangeable.
- Unitized, molded coil design.
- Manual override option.
- Optional waterproof E-Coils rated up to IP69K.
- Industry common cavity.

**RATINGS**

**Operating Pressure:** 207 bar (3000 psi); Under certain operating conditions, this valve may be used at higher pressures; consult factory.

**Proof Pressure:** 390 bar (5700 psi)

**Flow:** See Performance Chart

**Internal Leakage:** 0.15 cc/minute (3 drops/minute) max. at 207 bar (3000 psi)

**Temperature:** -40 to 120° C with standard Buna seals

**Coil Duty Rating:** Continuous from 85% to 115% of nominal voltage

**Initial Coil Current Draw at 20°C :** Standard Coil: 1.67 amps at 12 VDC; 0.18 amps at 115 VAC (full wave rectified).

E-Coil: 1.7 amps at 12 VDC; 0.85 amps at 24 VDC

**Minimum Pull-in Voltage:** 85% of nominal at 207 bar (3000 psi)

**Fluids:** Mineral-based or synthetics with lubricating properties at viscosities of 7.4 to 420 cSt (50 to 2000 sus)

**Installation:** No restrictions

**Cavity:** T16-2A; See bottom of this catalog.

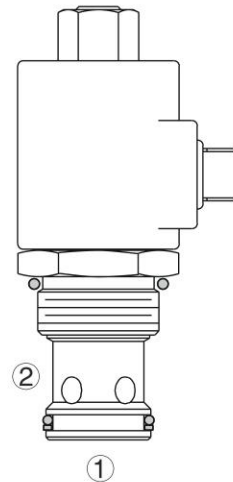

**ISO SYMBOL**

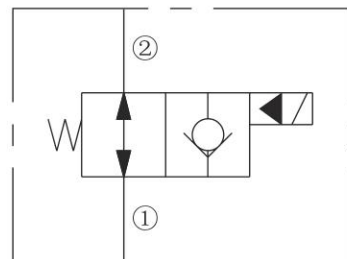

**PERFORMANCE (Cartridge Only)**

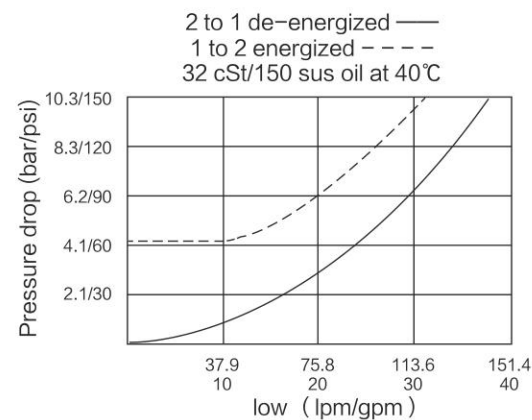

**DIMENSIONS**

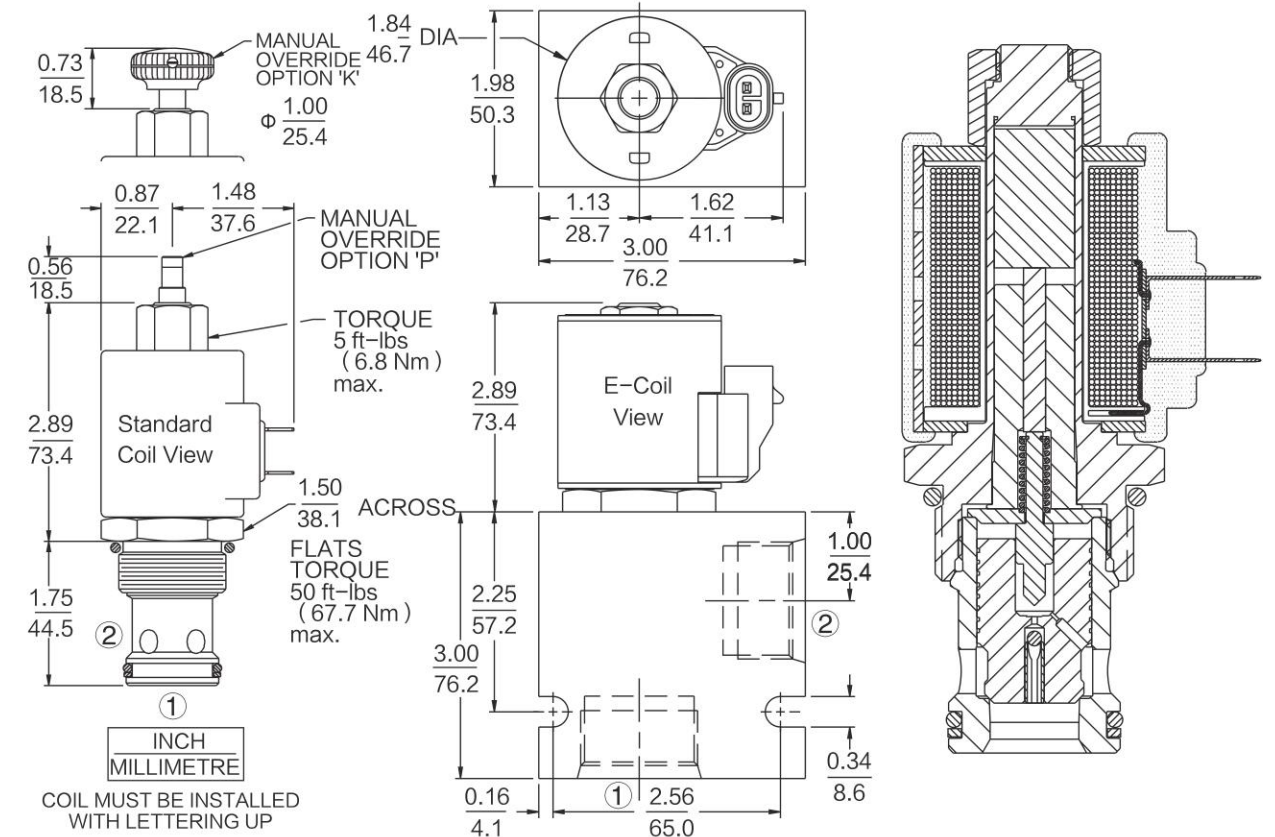

**MATERIALS**

**Cartridge:** Weight: 0.31 kg. (0.69 lbs.) Steel with hardened work surfaces. Zinc-plated exposed surfaces. Buna N O-rings and polyester elastomer back-up standard.

**Standard Ported Body:** Weight: 0.57 kg. (1.25 lbs.) Anodized high-strength 6061 T6 aluminum alloy, rated to 207 bar (3000 psi). Ductile iron bodies available; dimensions may differ.

**Standard Coil:** Weight: 0.27 kg. (0.60 lbs.) Unitized thermoplastic encapsulated, Class H high temperature magnetwire.

**E-Coil:** Weight: 0.41 kg. (0.9 lbs.) Fully encapsulated with rugged external metal shell. Rated up to IP69K with integral connectors.

**TO ORDER**

Option	Voltage Std. Coil	Termination (VDC) Std. Coil
None (Blank)	0 Less Coil**	DS Dual Spades
Manual Override without knob P	10 10 VDC†	DG DIN 43650
Manual Override with knob K	12 12 VDC	DL Leadwires (2)
	24 24 VDC	DLW Leads w/Weatherpak® Connectors
	36 36 VDC	DR Deutsch DT04-2P
	48 48 VDC	
	24 24 VAC	Termination (VAC) Std. Coil
	115 115 VAC	AG DIN 43650
	230 230 VAC	AP 1/2 in. Conduit Termination (VDC) E-Coil
		ER Deutsch DT04-2P (IP69K Rated)
		EY Metri-Pack® 150 (IP69K Rated)
		Coils with internal diode are available. Consult factory.
<b>Porting</b>	<b>E-Coil</b>	
Cartridge Only 0	10 10 VDC	
SAE 12 12T	12 12 VDC	
SAE 16 16T	20 20 VDC	
3/4 in. BSP* 6B	24 24 VDC	
1 in. BSP* 8B		
*BSP Body; U.K. Mfr. Only		
<b>Seals</b>		
Buna N (Std.) N		
Fluorocarbon V		